

# ROTOR NOZZLE

## Category Plant construction

### Operating Instructions



Year of construction 2010 ... + production quarter  
RA11-110, RA16-110, RA16-145, RA16-130,  
RA16-135, RA16-210, RA16-115, RA30-115,  
MA16-165  
BA 0304836 R01 2021-10

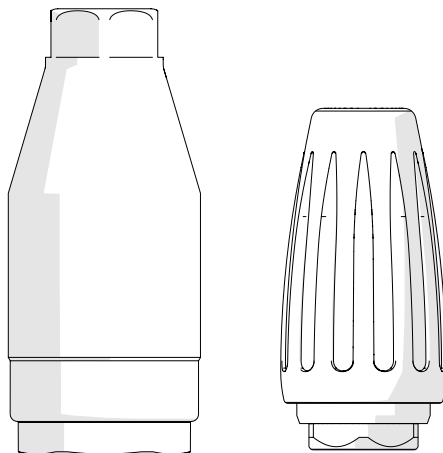

Operating instructions  
Rotor nozzles for plant construction



MADE  
IN  
GERMANY

TEV-JÄGER

 <b>Basics</b> .....	<b>5</b>
Safety notices	6
Explanatory information	7
Overview of the rotor nozzle components	8
Scope of delivery of the rotor nozzle	8
Tools required for assembly	9
Tools required for repair	9
How does a rotor nozzle work?	10
Components and their function	11
Intended use	13
Requirements for the surface to be cleaned	13
Requirements for the user of the system	13
Space requirement	13
Maximum performance data	13
Water quality for operation	13
Requirements for the high pressure cleaner	13
EC Declaration of Conformity	14
For your safety	16
 <b>Commissioning</b> .....	<b>18</b>
<b>Preparing and connecting the rotor nozzle</b> .....	<b>19</b>
Unpacking and checking	19
Mounting the rotor nozzle on the lance	19

 <b>Repair</b> .....	<b>22</b>
<b>Rotor nozzle defective</b> .....	<b>23</b>
Occurring error patterns .....	23
Troubleshooting measure .....	23
<b>Install repair kit</b> .....	<b>23</b>
Open pressure housing .....	23
Removing bearing unit .....	24
Inserting a new bearing unit .....	24
Inserting a new rotor .....	25
Changing the O-ring on the driving plug .....	25
Assembling the rotor nozzle .....	26
 <b>Disposal</b> .....	<b>28</b>
<b>What happens with the waste?</b> .....	<b>29</b>
Packaging .....	29
Protective cap, rotor, bearing unit .....	29
Pressure housing, driving plug .....	29
Consumable water .....	29



It is **IMPORTANT** that you read these operating instructions **CAREFULLY BEFORE USE** and to **KEEP FOR FUTURE REFERENCE**.

Visit our homepage at regular intervals and check for the latest version of the operating instructions.

The operating instructions are intended for..

Rotor nozzles from year of manufacture 1989. The operating manual has revision level R01.



# Components of a rotor nozzle and their function

Here you will find information about:  
the components of the rotor nozzle



# Explanation of notices

## Safety notices

These notices are for your safety. The notices can be found in the general part on safety and always at an action that requires a separate notice.



Failure to comply will lead to serious injury or death.



Failure to comply may lead to serious injury or death.



Failure to comply may lead to injuries.



Failure to comply may lead to material damage and impair the function of the product.

*Attention –*

Additional information about product operation.



## Explanatory information

This information can be found in the grey shaded illustration area. It helps you to find the right illustration for the heading in the text, to understand the details better, follow steps, complete movements and identify the position.

Clean thread

The title of the image indicates the **text** to which the figure belongs.

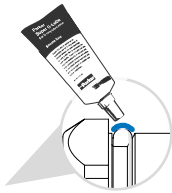

The detailed view highlights areas that are important.



The numbers on the figures are associated with the steps in the explanatory text. They always start anew at [1] on a double page.

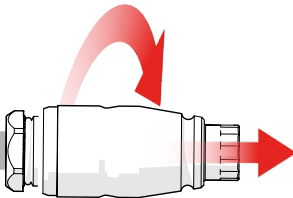

The red arrows always indicate a movement.



## Overview of the rotor nozzle components

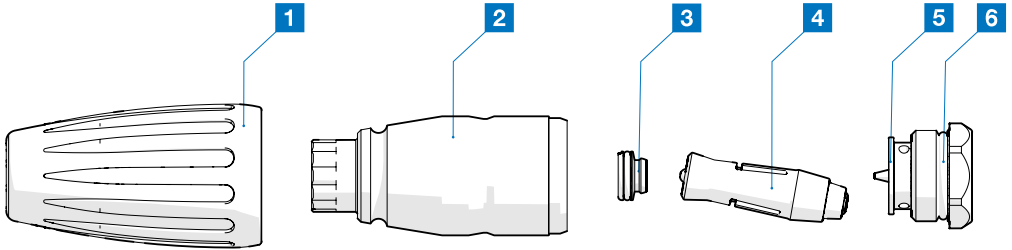

1 Protective cap (if fitted)

2 Pressure housing

3 Bearing unit

4 Rotor

5 Driving plug

6 O-ring

\* The rotor nozzle shown is exemplary.  
All types have the same components.

## Scope of delivery of the rotor nozzle

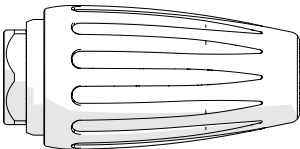

1 Rotor nozzle completely mounted





### Tools required for assembly

1

Combination spanners



2

LOCTITE 270



### Tools required for repair

1

Combination spanners



2

Mounting aid or  
e.g. pens



3

Assembly grease and lubricant  
Parker SUPER O-LUBE



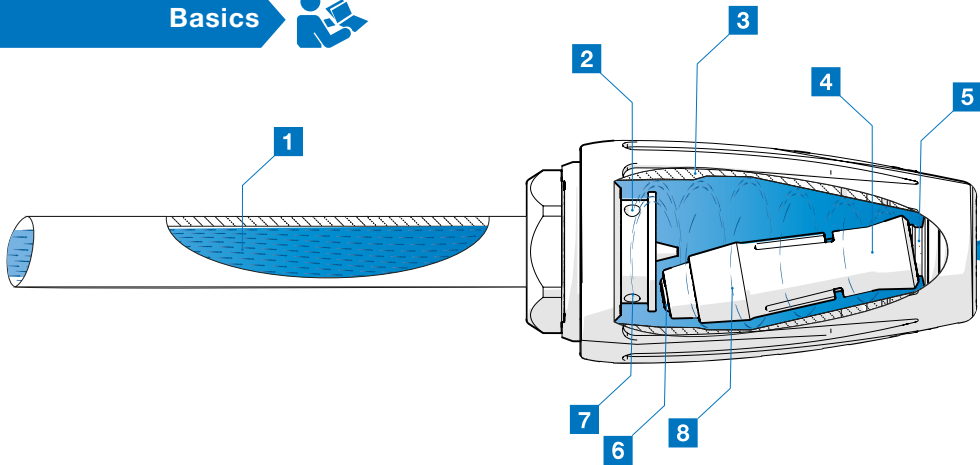

### How does a rotor nozzle work?

A rotor nozzle consists of a pressure housing, a driving plug, a rotor and a bearing unit.

The rotor nozzle produces a hard point jet of high-pressure water that rotates around an axial centre.

But how is the point jet set in rotation with the help of the high-pressure water?

1. At the beginning, the high-pressure water is **1** is fed into the driving plug via a supply line (high-pressure lance).
2. The high-pressure water emerges from the axially drilled holes **2** on the driving plug.
3. The high-pressure water fills the pressure housing **3**.
4. As the high-pressure water fills the pressure housing at a high velocity, the rotor is **4** is pushed into the bearing unit **5** and seals it against water leakage.

5. Now the high-pressure water can only exit the housing via the rotor **6** out of the housing via the rotor.

6. This creates a pressurised water flow.

7. As the water enters axially **7** through the holes of the driving plug, the water flow creates a rotating field **8**.

8. The resulting rotating field drags the rotor along. However, since the front part of the rotor is mounted in the bearing unit as a ball and cup, the rotor can only follow the rotating field with its rear part.

9. The centrifugal force acting on the rotor in the rotating field presses it against the pressure housing. In this way, the rotor completes a guided circular path.

10. This circular path is transferred to the point jet **9** which is generated by the water exiting via the rotor, thus creating the rotating point jet **10**. This creates the rotating point jet, which is then used to clean very effectively.

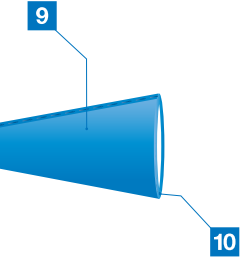

### Components and their function

- 1** The **protective cap** protects the pressure housing from direct impact and the operator from burns during hot water operation (not fitted to every type).
- 2** All components of the nozzle are **installed in the pressure housing**. It is the pressure body which, together with the driving plug, must withstand the specified maximum pressure.
- 3** The **driving plug** closes the pressure body and must withstand the pressure together with the pressure housing. In addition, the driving plug with its axial holes generates the rotating field that sets the rotor in rotation.
- 4** The **rotor** generates the backwater of the water with a built-in round nozzle. The desired water pressure is thus achieved in conjunction with the high-pressure cleaner. In addition to generating pressure, the rotor is also responsible for the circular path of the point jet.
- 6** The **O-rings** seal the pressure area on the driving plug and on the bearing unit.

1

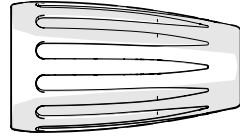

2

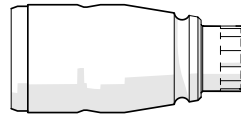

3

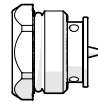

4

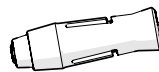

5



6





## Intended use

Here you will find the following information:  
For what purposes may the cleaner be used?  
Where may the cleaner be used? Who is  
allowed to use the cleaner?



### Intended use

The rotor nozzle is intended for surface cleaning with high-pressure water of non-organic surfaces.

### Requirements for the surface to be cleaned

The surface to be cleaned may not be organic. The surface must be suitable for being cleaned with a hard water jet.

### Requirements for the user of the system

*Qualified personnel:* Due to their technical training, knowledge, experience and familiarity with the relevant standards and regulations, qualified personnel are able to carry out the work assigned to them, to recognise possible dangers and to avoid risks independently.

*The following groups of people are not allowed to operate the rotor nozzle:*

- ▶ Persons with limited physical, sensory or mental abilities
- ▶ Children and young people under 18 years of age
- ▶ Persons who have not been trained

### Space requirement

See technical data of the respective type.

### Maximum performance data

The performance data depends on the type and can be found in the technical data of the individual types. The performance data given here are general data of this rotor nozzle category. The per-

formance data given here are general data of this rotor nozzle category.

- ▶ Working pressure: between 130 and 350 bar
- ▶ Speed point jet: 3,500 to 5,000 revolutions per minute
- ▶ Noise level during normal operation: 95 decibels
- ▶ Vibration value: 9 m/s<sup>2</sup>
- ▶ The volume flow depends on the type and can be found in the technical data of the individual types.
- ▶ The maximum water temperature depends on the type and can be found in the technical data for the individual types.

### Water quality for operation

- ▶ The rotor nozzle requires tap water.
- ▶ Make sure that the water does not contain any impurities

### Requirements for the high pressure cleaner

- ▶ The high-pressure cleaner must correspond to the performance data of the rotor nozzle. Please refer to the technical data of your type.



## EC Declaration of Conformity

Hersteller:

Produktbezeichnung: Rotordüse Standard "Anlagenbau" bis 350 Bar  
 Modellbezeichnung: Druckbereich Kennzahl 4, 05, 07, 10, 11, 15, 16, 18, 20, 21, 25  
 Typbezeichnung: RA11-110, RA16-110, RA16-145, RA16-130, RA16-135, RA16-210, RA16-115, RA30-115  
 Seriennummer: Produktionszeitraum in Quartal  
 Handelsbezeichnung: z.B. RA16-180-055-A  
 Baujahr: 1989  
 Beschreibung: Düse mit rotierendem Punktstrahl. Angetrieben durch einen Wasserhochdruck der von einem Hochdruckreiniger erzeugt wird.

allen einschlägigen Bestimmungen der angewandten Rechtsvorschriften (nachfolgend) - einschließlich deren zum Zeitpunkt der Erklärung geltenden Änderungen - entspricht. Die alleinige Verantwortung für die Ausstellung dieser Konformitätserklärung trägt der Hersteller. Diese Erklärung bezieht sich nur auf die Maschine in dem Zustand, in dem sie in Verkehr gebracht wurde; vom Endnutzer nachträglich angebrachte Teile und/oder nachträglich vorgenommene Eingriffe bleiben unberücksichtigt.

Folgende Rechtsvorschriften wurden angewandt:  
 Maschinenrichtlinie 2006/42/EG

Folgende harmonisierte Normen wurden angewandt:

EN 60335-2-79:2012	Sicherheit elektrischer Geräte für den Hausgebrauch und ähnliche Zwecke - Teil 2-79: Besondere Anforderungen für Hochdruckreiniger und Dampfreiniger (IEC 60335-2-79:2012 (modifiziert))
EN ISO 12100:2010	Sicherheit von Maschinen - Allgemeine Gestaltungsleitsätze - Risikobeurteilung und Risikominderung (ISO 12100:2010)
EN ISO 3744:2010	Akustik - Bestimmung der Schalleleistungs- und Schallenergiepegel von Geräuschquellen aus Schalldruckmessungen - Hüllflächenverfahren der Genauigkeitsklasse 2 für ein im Wesentlichen freies Schallfeld über einer reflektierenden Ebene (ISO 3744:2010)
EN ISO 4413:2010	Fluidtechnik - Allgemeine Regeln und sicherheitstechnische Anforderungen an Hydraulikanlagen und deren Bauteile (ISO 4413:2010)

Name und Anschrift der Person, die bevollmächtigt ist, die technischen Unterlagen zusammenzustellen:  
 Patrick Geiger, Dorfstrasse 16, 89185 Hüttisheim

Ort: Senden  
 Datum: 04.03.2021

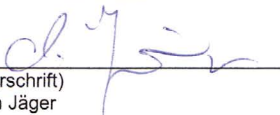
  
 (Unterschrift)  
 Anton Jäger

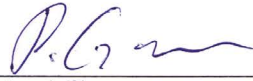
  
 (Unterschrift)  
 Patrick Geiger



# General safety instructions

Important instructions for safe use of the system and for establishing safe cleaning operations.



## For your safety

Here you will find information about choosing a safe cleaning location, sources of danger in the work area and sources of danger when working.

### CAUTION



#### Damage to hearing on account of too much noise

- ▶ Wear hearing protection while working. This will protect your hearing from damage caused by excessive noise.

### CAUTION



#### Risk of injury from overloading/strain

- ▶ Take regular breaks. This will prevent injuries caused by physical and mental overload and fatigue.

### CAUTION



#### Risk of injury from flying dirt and parts

- ▶ Wear safety goggles when working. This will protect you from injuries caused by flying dirt and loose parts.

### CAUTION



#### Risk of injury due to parts being flung away

- ▶ Check the surface to be cleaned for objects before starting cleaning. This will protect you from injuries caused by parts being flung away.

### NOTICE

#### Frost damage

- ▶ Make sure the rotor nozzle does not freeze up. This can cause damage to components. This protects the rotor nozzle against frost damage.





 **CAUTION**



**Risk of injury due to prolonged use of vibrating machinery**

- ▶ Take regular breaks.  
This prevents injury occurring due to physical or mental exhaustion.

 **CAUTION**



**Risk of injury from hot water**

- ▶ Watch out for leaks during hot water operation.  
This will protect you from scalding from hot water.

 **CAUTION**



**Risk of injury due to overriding of safety devices**

- ▶ Never override safety devices.  
This prevents injury caused by any uncontrolled motion of the rotor nozzle during start-up.



# Commissioning the rotor nozzle

Here you will find information about preparing the rotor nozzle for work.



## Preparing and connecting the rotor nozzle

Clean thread

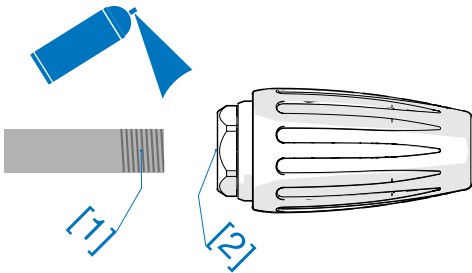

### Unpacking and checking

- ▶ Unpack the rotor nozzle.
- ▶ Check the rotor nozzle for external damage.
- ▶ Check whether all components are present.
- ▶ Check the functioning of the high-pressure gun.
- ▶ Check the connection threads on the rotor nozzle and the high-pressure lance

### Mounting the rotor nozzle on the lance

- ▶ Clean the thread of the connection [1] and the thread of the rotor nozzle [2] with a grease-dissolving cleaner. CAUTION – take care not to flush debris into the rotor nozzle.

Apply LOCTITE

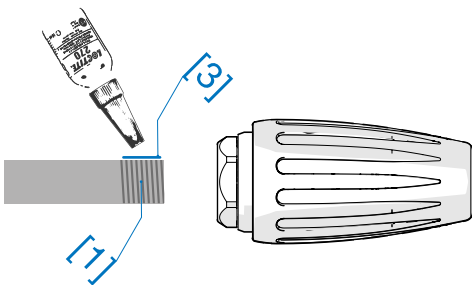

- ▶ Apply LOCTITE 270 as a line [3] lengthwise to the thread of the connection [1].



Screw on rotor nozzle

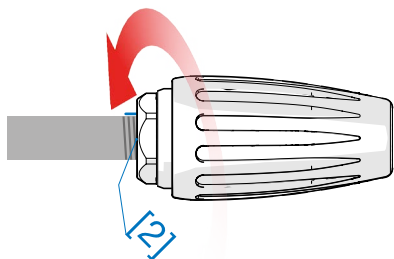

▶ Screw the rotor nozzle with the connection thread [2] onto the connection

▶ Place the combination spanner [4] on the hexagon of the driving plug [5].

▶ Screw the rotor nozzle tight with 15 Nm. CAUTION – the LOCTITE 270 has its final strength at room temperature after 6 hours.

Tighten the rotor nozzle

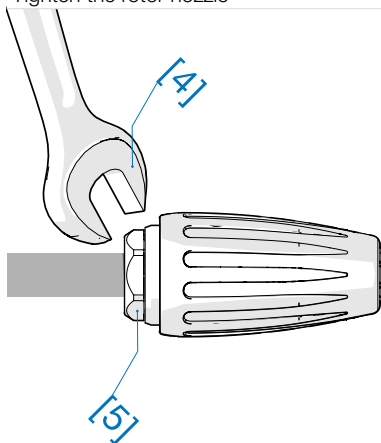

## CAUTION

### Risk of injury during installation

▶ Wear gloves during installation. This will protect your skin from abrasions and pinching.



**Notes**

KL01

KL02



## Repairing the rotor nozzle

Here you will find information about repairing the rotor nozzle.



## Rotor nozzle defective

Pull off the protective cap

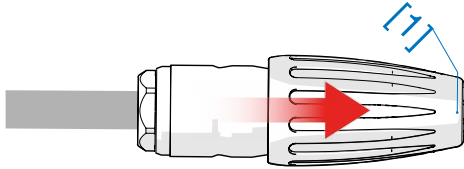

### Occurring error patterns

- ▶ No uniform cone
  - » Nozzle or bearing defective
- ▶ Uneven speed
  - » Nozzle or bearing worn
- ▶ Rotor nozzle has strong vibrations
  - » Rotor defective
- ▶ No rotation of the point jet
  - » Nozzle or bearing worn out

Attach ring spanner to multi-tooth

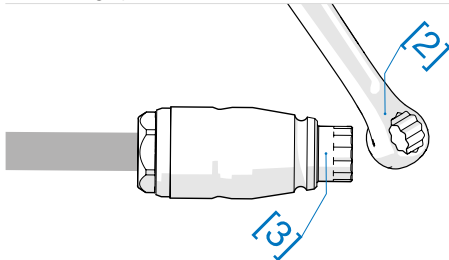

### Troubleshooting measure

- ▶ If the nozzle or bearing is defective or worn, a new rotor and bearing unit must be installed

## Install repair kit

Unscrew the pressure housing

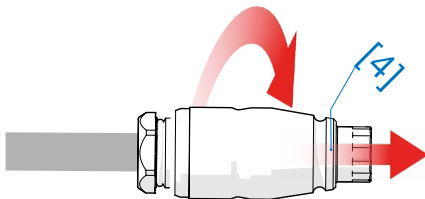

### Open pressure housing

- ▶ Pull off the protective cap [1] (if present).
- ▶ Set the combination wrench [2] on the spanner flats or the multi-toothing [3] of the pressure housing tip.
- ▶ Unscrew the pressure housing [4] from the driving plug.



Remove rotor

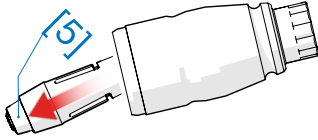

- ▶ Remove the old rotor [5] from the pressure housing.

### Removing bearing unit

- ▶ Take the dismantling assembly aid [6] and press the bearing unit [7] from the outside inwards out of the pressure housing.

- ▶ Clean any dirt from the pressure housing.

Unscrew the pressure housing

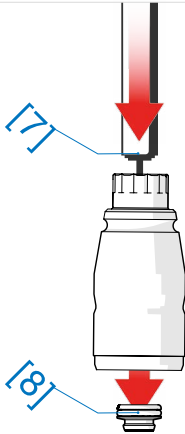

### Inserting a new bearing unit

- ▶ Take the new bearing unit [8] and grease [9] the O-ring.

### ⚠ CAUTION

#### Risk of injury from unintentional start-up

- ▶ Always disconnect the rotor nozzle from the high-pressure cleaner during maintenance work. This will prevent personal injury and damage to property due to uncontrolled start-up.

Grease O-ring

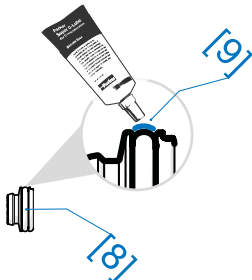

### ⚠ CAUTION

#### Risk of injury during disassembly

- ▶ Wear gloves during disassembly. This will protect your skin from abrasions and pinching.





Bearing unit on mounting aid

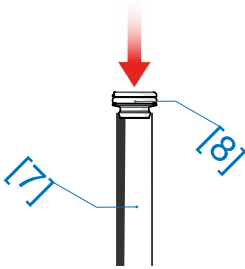

► Place the bearing unit [8] with the bearing seat first on the [7] disassembly assembly aid.

► Place the pressure housing [10] over the disassembly aid in your hand and press the bearing unit as far as it will go.

### Inserting a new rotor

► Take the new rotor [11] and place it in the pressure housing with the nozzle first.

► Push the rotor until it rests properly in the bearing unit.

Insert bearing unit

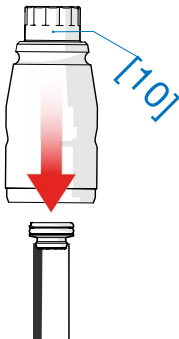

Insert rotor

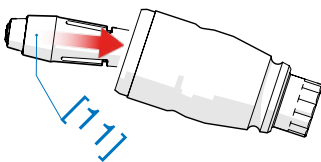

Drawing assembly aid

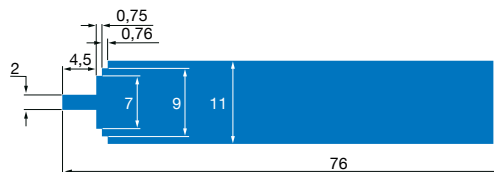



Remove O-ring

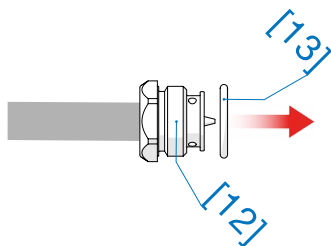

Mount and grease the O-ring

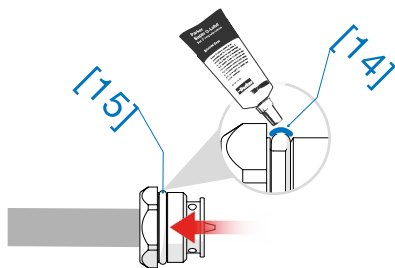

Unscrew the pressure housing

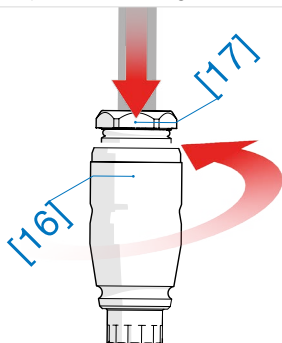

### Changing the O-ring on the driving plug

- ▶ Remove the old O-ring [13] from the driving plug [12].
- ▶ Clean the driving plug.
- ▶ Fit the new O-ring [14].
- ▶ Grease [15] the O-ring and the thread.

### Assembling the rotor nozzle

- ▶ Hold the pressure housing [16] horizontally with the opening to the driving plug.
- ▶ Screw the pressure housing [16] onto the driving plug [17] as far as it will go. ATTENTION – the rotor may not be jammed.



Tighten the pressure housing with 25 Nm

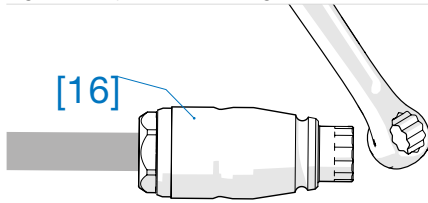

► Screw the pressure housing [16] tight with 25 Nm.





## Dispose of rotor nozzle

Information about disposal of the product and the associated components can be found here.



# What happens with the waste?



## Packaging

- ▶ The packaging is made of cardboard and can be recycled.

## Protective cap, rotor, bearing unit

- ▶ These components can be disposed of with non-recyclable waste.

## Pressure housing, driving plug

- ▶ These components can go into metal recycling.

## Consumable water

- ▶ The water that is contaminated by the cleaning process must be disposed of in accordance with the regulations in the event of environmentally harmful contamination.

## CAUTION

### Risk of injury during disassembly

- ▶ Wear gloves during disassembly. This will protect your skin from abrasions and pinching.

